

Charged Up - Teacher Notes

Materials

Adjust the materials for each experiment to match the number of students in your classroom.

Capacitor #1:

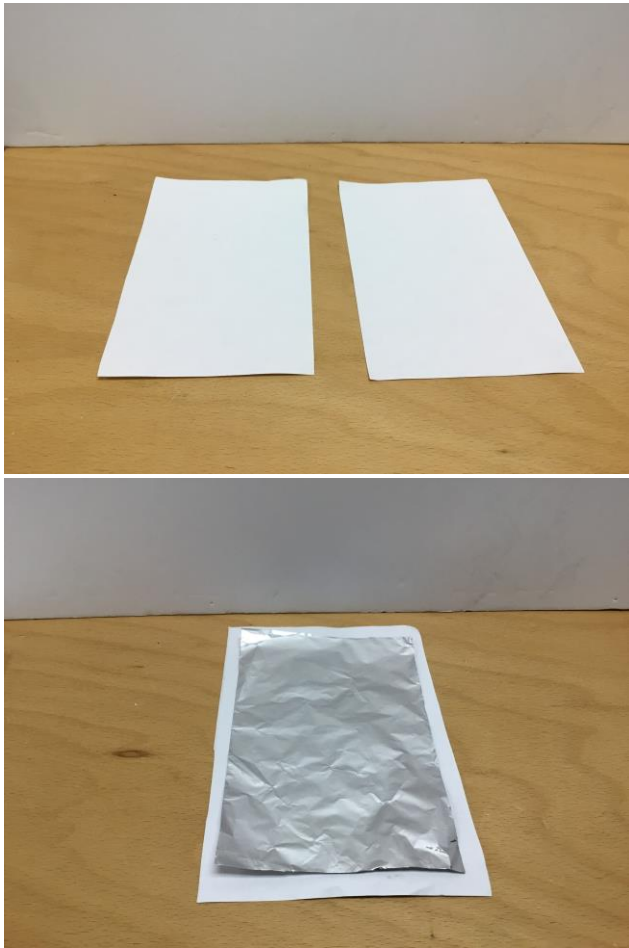

- 2 white sheets 8.5 x 11" printer paper x # students
- Aluminum foil x # students
- Masking tape - this should be included in the kit, students will be sharing the masking tape
- 2 alligator clips x # students
- Wire - this should be included in the kit, students will be sharing this wire
 - wire strippers can be used to strip the wire bare

Capacitor #2:



- 2 white sheets 8.5 x 11" printer paper x # students
- Aluminum foil x # students
- Masking tape - this should be included in the kit, students will be sharing the masking tape
- Wire - this should be included in the kit, students will be sharing this wire
 - wire strippers can be used to strip the wire bare
- 2 alligator clips x # students

Battery vs Capacitor

When explaining the difference between batteries and capacitors, make sure to emphasize that capacitors do not create power unlike batteries. Capacitors only store energy and release the energy quickly. Batteries create electrical energy by a chemical reaction between protons and electrons inside the battery.

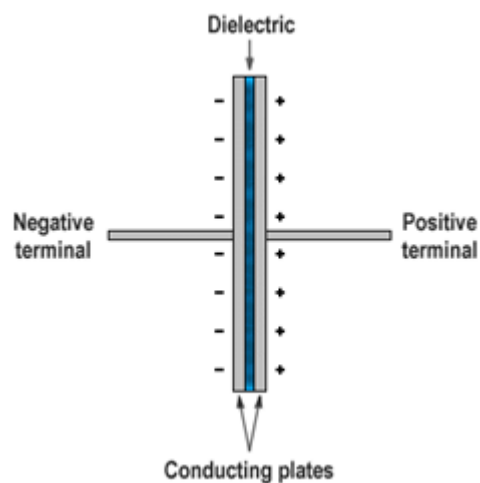
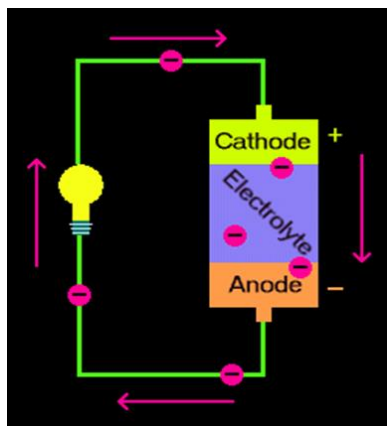

Do these batteries have an effect on the environment?

Problem: If batteries are not properly disposed after usage, chemical degradation can take place and the corrosive materials in batteries can cause harm to the environment.

Solution: Manufacturers and retailers are working continuously to reduce the environmental impact of batteries by producing designs that are more recyclable and contain fewer toxic materials.

Problem: Production, transportation and distribution of batteries consumes natural resources, thereby contributing to an accelerating depletion of natural resources.

Solution: Rechargeable batteries consume less nonrenewable natural resources than disposable batteries because fewer rechargeable batteries are needed to provide the same amount of energy.

How might we use capacitors in our everyday lives? Guess a few technologies that might use them?

- Flash circuit of a camera - need a buildup of energy and then a sudden release
- Hybrid electric vehicles
- Smartphone touch screens

Capacitor Design and Build

When creating capacitors, these characteristics will affect your capacitance (how much charge the capacitor is able to store):

- Greater plate area gives greater capacitance
 - Larger plate area results in more field flux (charge collected on the plates) for a given field force (voltage across the plates)
- Further plate spacing gives less capacitance; closer plate spacing gives greater capacitance
 - Closer spacing results in a greater field force (voltage across the capacitor divided by the distance between the plates), which results in a greater field flux (charge collected on the plates) for any given voltage applied across the plates
- Greater permittivity of the dielectric gives greater capacitance; less permittivity of the dielectric gives less capacitance.
 - Permittivity: measure of resistance that is encountered when forming an electric field in a particular medium
 - Some materials offer less opposition to field flux for a given amount of field force
 - Materials with a greater permittivity allow for more field flux (offer less opposition), and thus a greater collected charge, for any given amount of field force (applied voltage)
 - For example, glass has greater permittivity than air. So, sticking a glass plate between two capacitor plates will establish a stronger electric field flux than air. As a result, more charge can be stored in a capacitor if a glass dielectric is used.

TABLE 7-1. Dielectric Constants for Common Materials.

MATERIAL	CONSTANT
Vacuum	1.0000
Air	1.0006
Paraffin paper	2.5 - 3.5
Transformer oil	4
Glass	5 - 10
Mica	3 - 6
Rubber	2.5 - 35
Wood	2.5 - 8
Porcelain	6
Glycerine (15 C)	56
Petroleum	2
Pure water	81

CAPACITOR RATING

Testing and Measuring Capacitor Functionality

- While charging the capacitor, measure the voltage with a voltmeter while the power source (9V battery) is connected to measure the voltage.
 - The voltage read while the battery is connected should be close to the 9V value of the battery.
- Disconnect the capacitor from the battery by disconnecting the alligator clips from the power source itself. This prevents the student from accidentally discharging by touching the capacitor directly.
- The capacitor should discharge fairly quickly

Reflection

- What might be an example of a capacitor in nature?
 - Lightning - a giant “spark” occurs because there is a large charge separation in the cloud where protons and electrons separate and accumulate.

- Like a capacitor, the energy is released very quickly
- What might be some items you use everyday that store energy?
 - Microwave - stores energy so that it can be released and used to heat up food
 - Speakers - capacitors act as amplifier to make the output sound louder
 - Generator - power hospitals and important buildings just in case the power goes out
- How might capacitors be used to increase the production of renewable energy?
 - Instead of wasting energy (e.g. capturing energy that a light bulb wastes from producing heat) - it can possibly recapture that energy and store it so that more energy can be created

